

# 801 FLOW METER

## INSTALLATION, SPECIFICATION, AND WARRANTY INFORMATION

Please read before installing this equipment. Failure to do so may void your warranty.

### Installation

The 801 flow meter gives the best accuracy when there is a smooth, unobstructed flow through it. To minimize turbulence, there should be at least twelve inches of straight plumbing upstream from the flow meter and at least 6 inches of straight plumbing downstream from the flow meter. Mount the flow meter in a location that physically protects it from damage and allows liquid to drain away after the sprayer is flushed and secured at the end of the operating day. A straight, vertical section of the main boom supply line is the ideal location for the flow meter.

**Keep the flow meter from lying in a low section of the sprayer plumbing.** This is particularly important in cold weather when water might freeze in the flow meter and cause damage to the unit. It is also important when applying chemical suspensions which may settle out and stall the flow meter turbine if they cannot drain away.

Before installing the flow meter insert, make sure there are no obstructions in the insert cavity. Clearance at the bottom of the cavity is very close and over tightening or compressing of foreign material in the cavity can cause damage to the flow meter body. Turn the insert in until it is hand tight.

Prior to each day's spraying, the flow meter should be inspected to ensure there are no leaks around the attachment fittings. At the end of the day, care should be taken to thoroughly flush the flow meter with clean water.

### Make sure no water or sediment is trapped in the flow meter

The impeller type flow meters supplied by TeeJet Technologies are inherently rugged. However, continued use over time will eventually wear the internal bearings and shafts until the meter becomes inaccurate. Replacement kits are available to repair the flow meters. Contact your TeeJet Technologies dealer for these parts.

### 801 FLOW METER

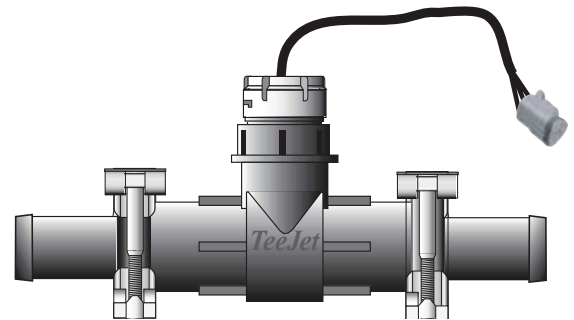

Housing, Deutsch 3 Pos/Skts		
Pin Out	Color	Function
A	Red	+12V
B	White	Signal
C	Black	Ground

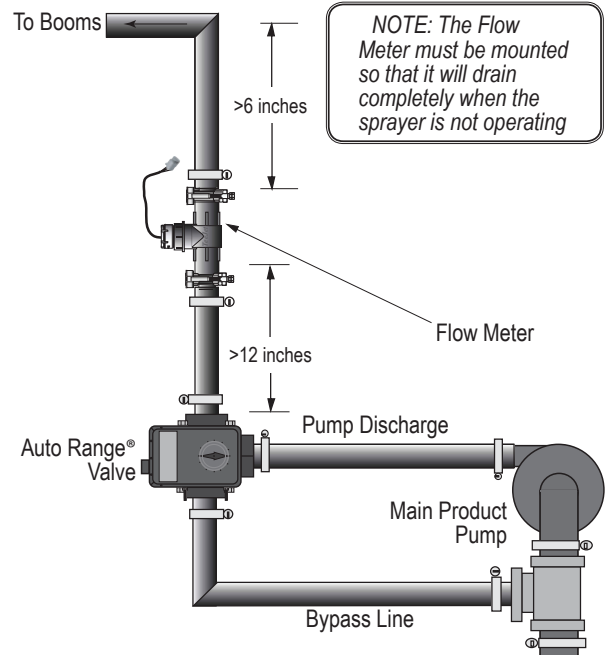
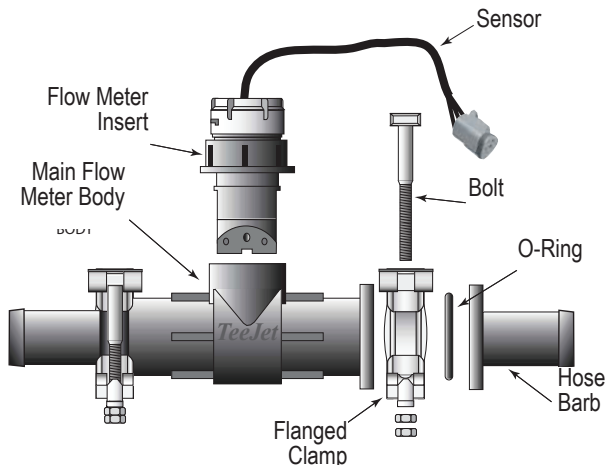

## Specifications

The 801 Flow Meter meets the following specifications:

Measuring Data	
Linearity at recommended flow range	+/- 3.0%
Flow Range	2-60 GPM (7.5-225 LPM) (3-30 GPM recommended for max life)
Maximum Working Pressure	300 PSI (20.7 Bar)
Pressure Drop	10 GPM (37.85 LPM) - NA 20 GPM (75.71 LPM) - 3 PSI (0.21 Bar) 30 GPM (113.56 LPM) - 7.5 PSI (0.52 Bar) 40 GPM (151.42 LPM) - 12.5 PSI (0.86 Bar) 50 GPM (189.27 LPM) - 19.5 PSI (1.34 Bar) 60 GPM (227.12 LPM) - 29 PSI (2.0 Bar)
<i>Measuring range is partly dependent on the selected type and size of connectors.</i> <b>The flow meter is bi-directional for mounting purposes.</b>	

Electrical Data	
Sensor	Open collector NPN 50% square wave 10-300 Hz in operating range
Calibration Number (Approximate)	TeeJet Controller 82 pulses/liter, Mid-Tech 310 pulses/gallon
LED Indicators	Green-Power Orange-Signal

Measuring Data	
Body & Insert	30% glass filled polypropylene
Shaft	410 hardened stainless steel
Turbine & Bearing Support	20% talc filled polypropylene
Bearing	Sapphire
Bearing Housing	303 stainless steel

## Warranty

The warranty on this equipment may be affected for the following reasons:

- Improper installation
- Obvious abuse
- Lack of, or improper maintenance
- Employed in a manner inconsistent with its intended use
- Used with chemicals that are incompatible with the materials which this product is made of

(See "Warranty and Limitations" statement in your controller manual for other limitations)

This flow meter is manufactured using some or all of the following materials:

- 303 Stainless Steel
- 410 Stainless Steel
- Polypropylene

TeeJet Technologies does not recommend metering any product that reacts with these materials and damage resulting from the use of such products will not be covered under the warranty. Please contact your chemical supplier to verify that the chemicals you are using are compatible.

If you have any questions about installation or use, refer to the installation section of your manual or call your TeeJet Technologies dealer.



TeeJet Technologies  
1801 Business Park Drive  
Springfield, Illinois 62703 USA  
Tel: (217) 747-0235 • Fax: (217) 753-8426  
[www.teejet.com](http://www.teejet.com)